

Quickwire

Prewired Maintenance Free Junction Boxes

Switch & Load

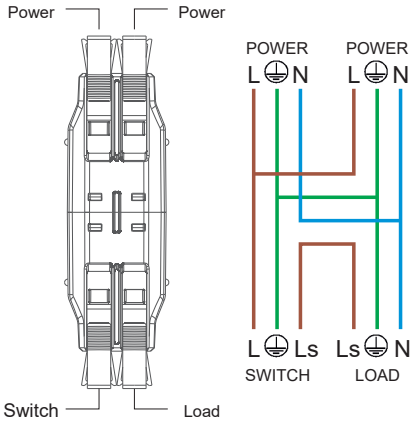

Splitter

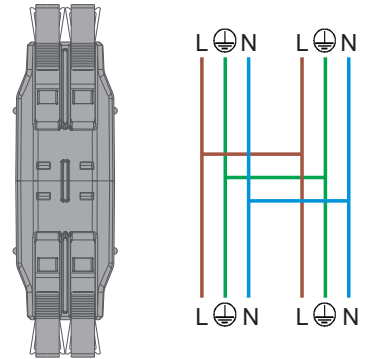

Rating	16A, 250V a.c.
Conductor Size	1.0mm ² – 1.5mm ² Twin & Earth CPC Cable (6242Y or 6242B), Solid cores (Class 1)
Dimensions	23mm x 31mm x 84mm (Wired)
IP Rating	IP30
Standards	BS EN60670-22 BS 5733-MF
Patent pending PCT/GB2016/053627 Reg.Design.6004582 This product is designed for lighting installations only. Overcurrent protection is limited to 16A max. Circuit to be protected by 16A MCB max.	



Cable Preparation

Cut and strip the 1.0mm² / 1.5mm² solid core, flat twin and earth cable as shown below:

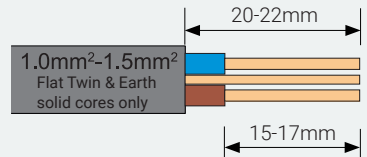

This product should be installed by a qualified electrician, ensuring the installation complies to the current IET wiring regulations. Switch off mains supply before commencing any electrical work.

+44 (0)1183 840025 | Info@quickwire.co.uk | www.quickwire.co.uk

Quickwire Limited, 6 Tavistock Industrial Estate, Ruscombe Lane, Twyford, Berkshire RG10 9NJ, UK

A flexconnectors Company

Installation

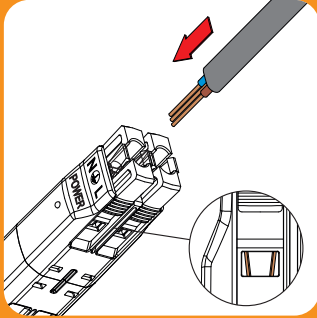

Orientate and align pre-cut cable and insert into appropriate cable entry point. Each wire should guide itself into the correct terminal. Push cable until there is resistance.

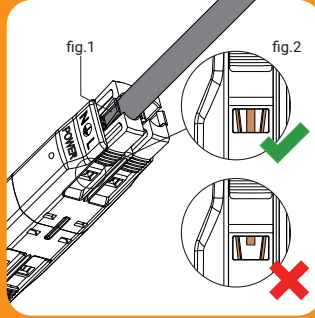

Check there is a sufficient length of outer cable sheath available for clamping. (fig.1) and that an unbroken length of conductor occupies the full extent of the window (fig.2).

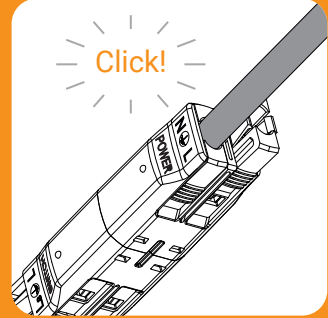

Push cable until it snaps into place. Repeat process for additional cables. Push in any unused cable entries.

Fixing

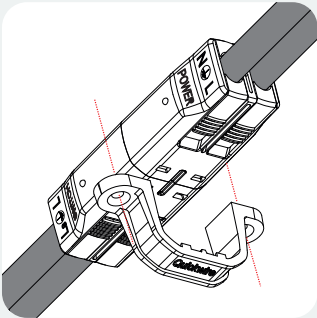

If required the Quickwire can be fitted onto a surface using the Quickwire mounting clip.

Warning: Do not cover

Cable Removal

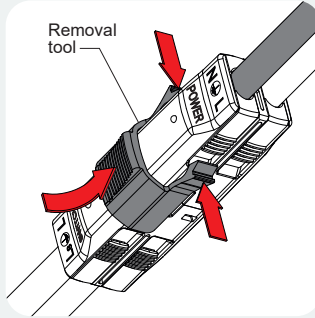

Mount removal tool. Place thumb on thumb grip and using other hand, squeeze side arms so they locate beneath the snaps.

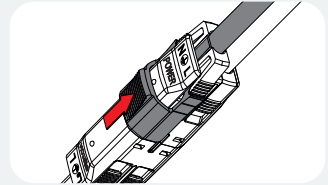

Press down on thumb grip and push forward until removal tool stops.

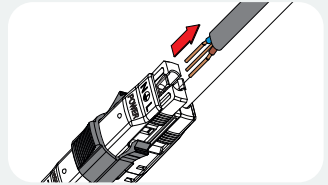

Release removal tool and pull out cable.

+44 (0)1183 840025 | Info@quickwire.co.uk | www.quickwire.co.uk

Quickwire Limited, 6 Tavistock Industrial Estate, Ruscombe Lane, Twyford, Berkshire RG10 9NJ, UK

A flexconnectors Company