

# Data Sheet : LG220NMB



Intertek



Electrical & Lighting Products

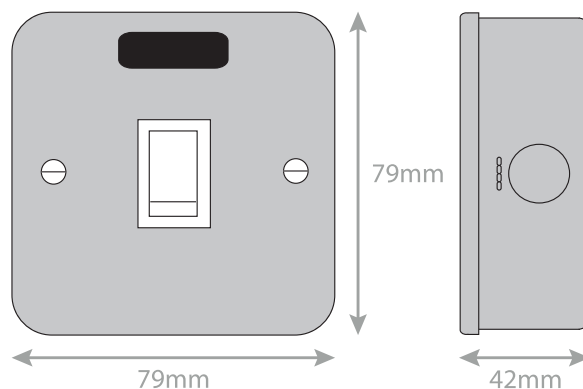
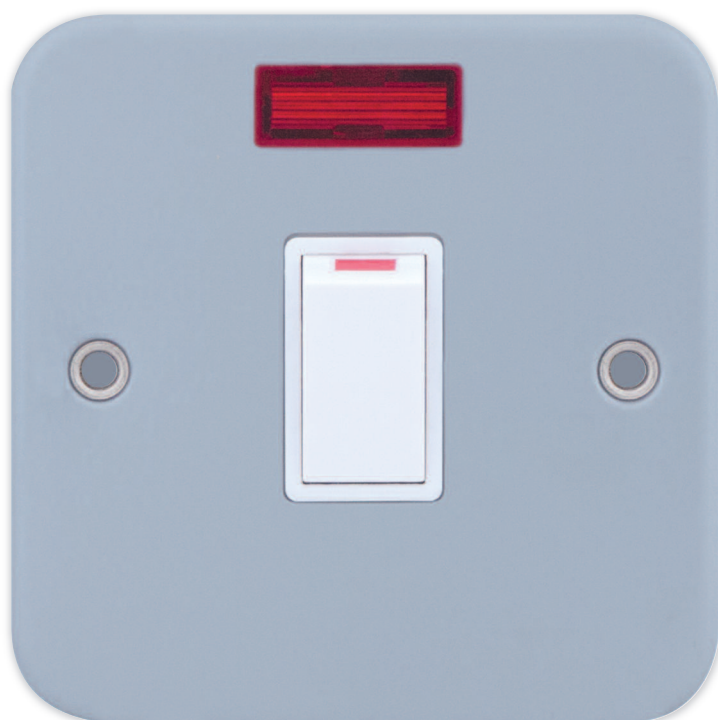

<b>Code</b>	LG220NMB
<b>Description</b>	20 Amp DP Switch with Neon
<b>Size</b>	79mm x 79mm x 42mm depth
<b>Range</b>	Selectric Metal Clad
<b>Colour</b>	Grey with white insert
<b>Material</b>	High grade steel with aluminium epoxy powder coating
<b>Included</b>	Back box & M3.5 fixing screws
<b>Weight</b>	0.3kg
<b>Inner Carton Quantity</b>	10
<b>Inner Carton Weight</b>	3kg
<b>Guarantee</b>	15 years
<b>Barcode</b>	5025117012208
<b>Commodity Code</b>	8539 319090
<b>Standards</b>	BS EN 60669-1
<b>Notes</b>	<ul style="list-style-type: none"> <li>• ASTA approved</li> <li>• For use with equipment such water heaters</li> <li>• Modular and Euro Media products available within the range</li> <li>• Surface mounting box included</li> </ul>