

Data Sheet :

LG220MB



Intertek



Electrical & Lighting Products

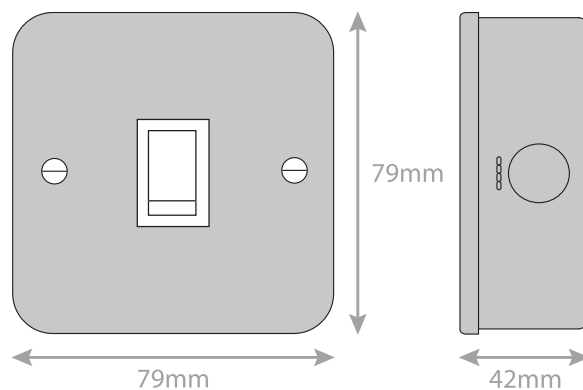
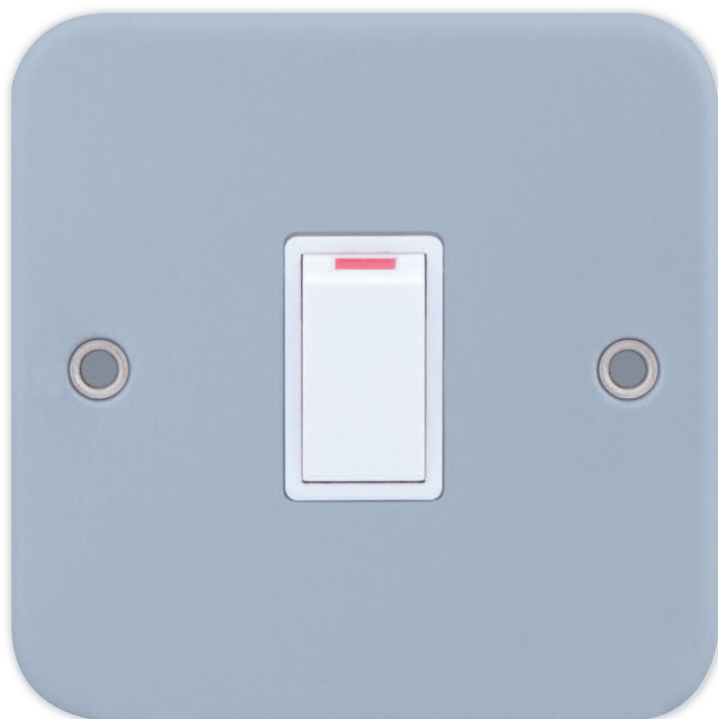

Code	LG220MB
Description	20 Amp DP Switch
Size	79mm x 79mm x 42mm depth
Range	Selectric Metal Clad
Colour	Grey with white insert
Material	High grade steel with aluminium epoxy powder coating
Included	Back box & M3.5 fixing screws
Weight	0.3kg
Inner Carton Quantity	10
Inner Carton Weight	3kg
Guarantee	15 years
Barcode	5025117012215
Commodity Code	8539 319090
Standards	BS EN 60669-1
Notes	<ul style="list-style-type: none"> • ASTA approved • For use with equipment such water heaters • Modular and Euro Media products available within the range • Surface mounting box included