

CHANNEL

SAFETY SYSTEMS

Vale



LED emergency exit signage
from Channel Safety Systems



LED Emergency Exit Sign

The Vale Emergency exit sign utilises LED technology with the added advantage of 'self-test' operation. Vale is designed to be fully recessed; available in several finishes allowing the unit to meet with the end users decorative requirements. Vale is supplied as standard with a 7mm blade which ensures the required even distribution of light throughout its surface.

Features

- Self-test operation as standard to BS EN 62034
- Low running costs (8.5 W)
- 24 x 0.07W LEDs
- Long life LED technology
- Maintained or non-maintained 3 hour emergency backup (can be switched to non-maintained if required)
- Double sided legend, supplied as standard with arrow up
- Housings available in white metal, brass or chrome
- Incorporates 2.4 NiHH 1800mAh battery
- Minimal maintenance required
- Additional pictograms available to fit in with your existing scheme
- Meets BS EN 60598-2-22 and other relevant standards

Please note

The Health and Safety Signs and Signals Regulations i, SI 341, introduced in 1996 to enact the EU Signs Directive ii, required that all text-only fire safety signs (i.e. EXIT or FIRE EXIT signs) produced to comply with BS 2560 should be replaced by 24th December 1998 with the pictogram format "running man" signs.

Consideration should not only be given to updating signs by changing the legend panels or diffusers, but also to taking the opportunity to test the installed signage products. Testing will often reveal that the internal battery also needs replacing. Replacement of just the legend panels or diffusers may be difficult if the sign luminaire type has been discontinued by the maker. This, combined with the possible need to replace the internal battery, will usually mean that it is more cost effective to replace the whole luminaire.



www.channelsafety.co.uk

Tel: 0845 884 7000

Email: sales@channelsafety.co.uk

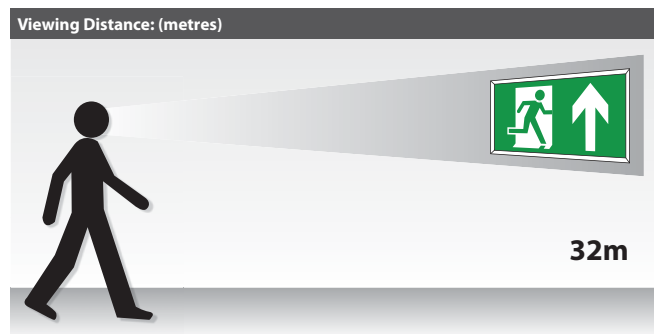
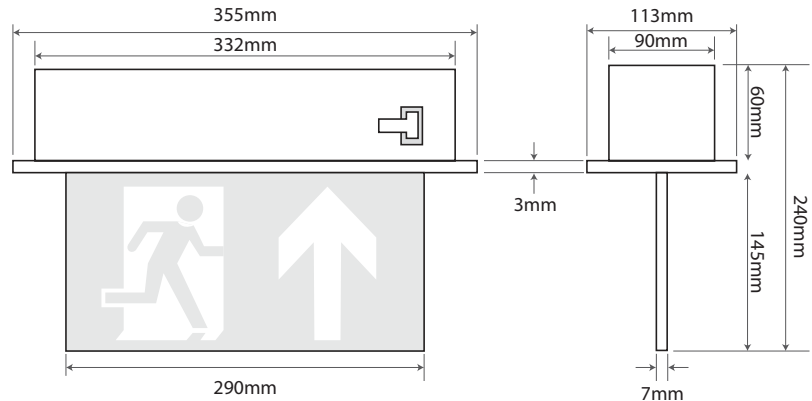

Please note image shown is not to scale and is for pictorial reference only

SPECIFICATIONS	
Light Source	24 white LEDs
IP Rating	IP40
Emergency Duration	3 hours (minimum)
Mains Voltage	230V 50Hz ± 10%
Mains Current (max)	35mA (max) (8.5W)
Recharge Period	Less than 24 hours
Charge Indicator	Integral green LED
Changeover Voltage	230V 50Hz ±10%
Temperature Range	-10°C - +55°C (Non Condensing)
Weight	1.5Kg
Battery	2.4 NiHH 1800mAh

PRODUCT CODE	DESCRIPTION
E/CHVL/M3/L/WHST	Vale LED 3 hour maintained white self-test complete with legend arrow up
E/CHVL/M3/L/BRST	Vale LED 3 hour maintained brass complete with legend arrow up
E/CHVL/M3/L/CHST	Vale LED 3 hour maintained chrome complete with legend arrow up
S/LEG/VL/AD	Vale double sided arrow down legend (insert only)
S/LEG/VL/ALR	Vale double sided arrow left/right (insert only)
S/LEG/VL/AU	Vale legend arrow up (insert only)

Errors & omissions excluded. Specification is subject to change without notice.